

TANKS À LAIT MILKCOOLING TANKS

2 TRAITES 2 MILKINGS

IC50 → IC300

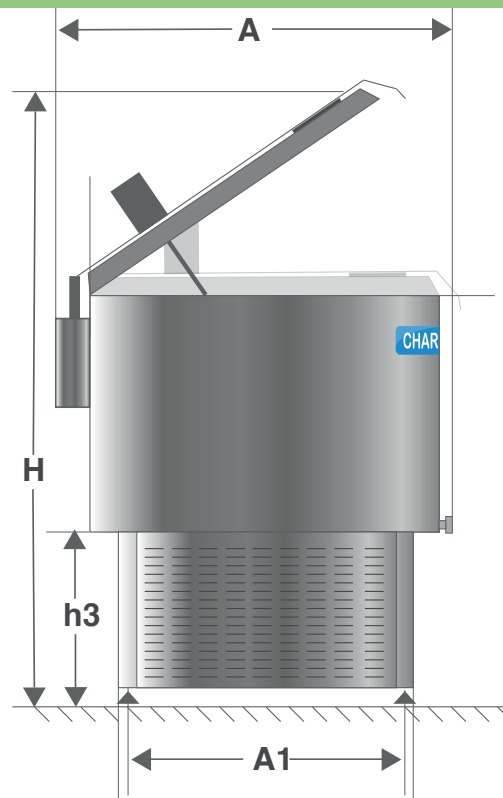
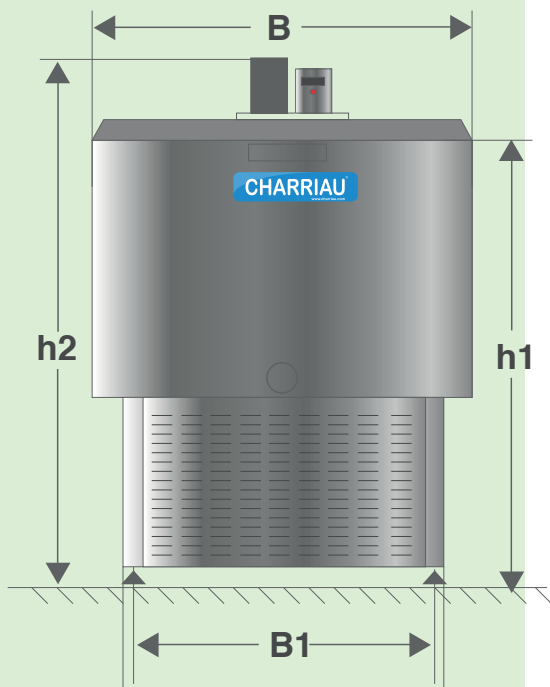

DIMENSIONS

Modèle Model	A	A1	A2	B	B1	B2	H	h1	h2	h3
IC50	560	280	365	520	280	365	1350	820	1050	440
IC100	780	330	400	680	410	500	1660	980	1190	420
IC200	1030	530	610	890	530	610	1520	990	1220	420
IC300	1130	530	620	990	530	610	1700	1030	1250	420

DÉTAILS TECHNIQUES TECHNICAL DETAILS

Modèle Model	Capacité maxi Maximum capacity	Poids Weight	Groupe frigorifique Cooling unit	Voltage tension	Gaz frigo Gas	Capacité réfrigér. Cooling capacity	Puissance max Maximum power rate	Courant nominal Run current	Courant max Maximum current	Traite Milking
IC50	51	52	AEZ 9440Z L'UH	220V-240V 50Hz, 1~	R449	835W 1/3Hp	580W	3,52A	3,52A	2
IC100	125	72	NEK6210GK EMBRACO	220V-240V 50Hz, 1~	R449	1023W 1/2Hp	703W	4,03A	4,54A	2
IC200	245	110	NT6224GK EMBRACO	220V-240V 50Hz, 1~	R449	2190W 1Hp	1303W	6,27A	7,30A	2
IC300	336	128	NJ9232GK EMBRACO	220V-240V 50Hz, 1~	R449	2578W 1_1/4Hp	1612W	7,67A	9,16A	2
IC300T	336	128	TAJ9513 L'UH	380V-400V 50Hz, 3~	R449	2578W 1_1/4Hp	1450W	3,10A	4,47A	2

CHARRIAU
www.charriau.com

10, rue des Peupliers
44270 SAINT ETIENNE DE MER MORTE
Tel ; 02 40 31 18 72 Fax ; 02 40 31 18 73
www.charriau.com - contact@charriau.com