

TANKS À LAIT MILKCOOLING TANKS

2 TRAITES 2 MILKINGS

IC400 → IC2500

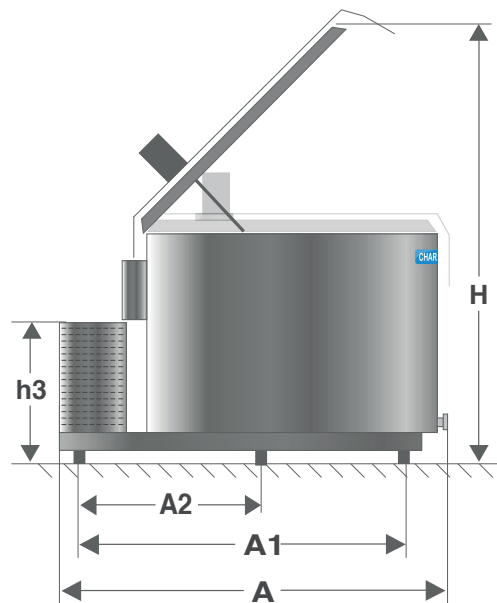
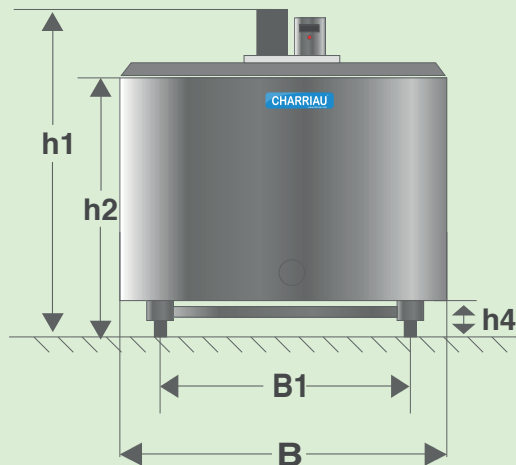

DIMENSIONS

Modèle Model	A	A1	A2	B	B1	H	h1	h2	h3	h4
IC400	1670	950	-	1090	670	1555	1050	830	685	180
IC500	1620	950	-	1090	670	1705	1190	965	685	180
IC650	1600	950	-	1090	670	1830	1345	1120	685	180
IC800	2140	1630	-	1290	925	1985	1265	1040	685	192

DÉTAILS TECHNIQUES TECHNICAL DETAILS

Modèle Model	Capacité maxi Maximum capacity	Poids Weight	Groupe frigorifique Cooling unit	Voltage tension	Gaz frigo Gas	Capacité réfrigér. Cooling capacity	Puissance max Maximum power rate	Courant nominal Run current	Courant max Maximum current	Traite Milking
IC400T	426	170	TAJ4519Z L'UH	380V-400V 50Hz, 3~	R449	3998W 1,5Hp	2124W	4,92A	5,90A	2
IC400	426	170	NJ9238 EMBRACO	220V-240V 50Hz, 1~	R449	3811W 1,5Hp	2149W	10,14A	16,00A	2
IC500	532	176	NJ9238 EMBRACO	220V-240V 50Hz, 1~	R449	3811W 1,5Hp	2149W	10,14A	16,00A	2
IC500T	532	176	TAJ4519Z L'UH	380V-400V 50Hz, 3~	R449	3998W 1,5Hp	2124W	4,92A	5,90A	2
IC650	659	202	FH4524Z L'UH	220V-240V 50Hz, 1~	R449	4267W 2Hp	2396W	10,74A	19,20A	2
IC650T	659	202	TFH4524Z L'UH	380V-400V 50Hz, 3~	R449	4288W 2Hp	2399W	5,16A	8,80A	2
IC800	849	254	FH4531Z L'UH	220V-240V 50Hz, 1~	R449	6219W 2,5Hp	3186W	14,05A	24,15A	2
IC800T	848	254	TFH4531Z L'UH	380V-400V 50Hz, 3~	R449	6139W 2,5Hp	3066W	6,48A	10,75A	2

CHARRIAU
www.charriau.com

10, rue des Peupliers
44270 SAINT ETIENNE DE MER MORTE
Tel ; 02 40 31 18 72 Fax : 02 40 31 18 73
www.charriau.com - contact@charriau.com

TANKS À LAIT MILKCOOLING TANKS

**2 TRAITES
2 MILKINGS**

IC400 → IC2500

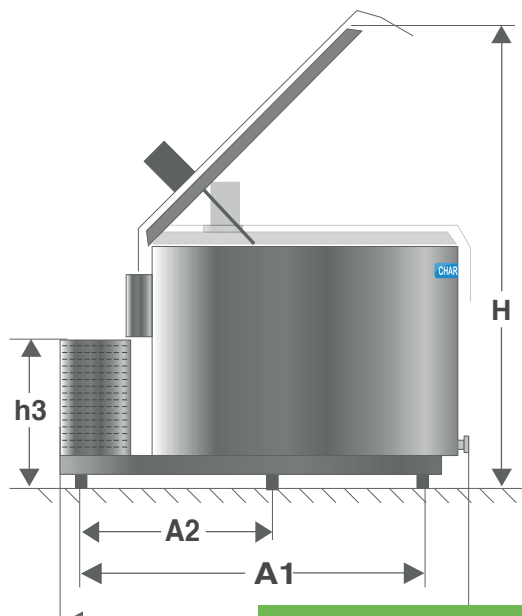
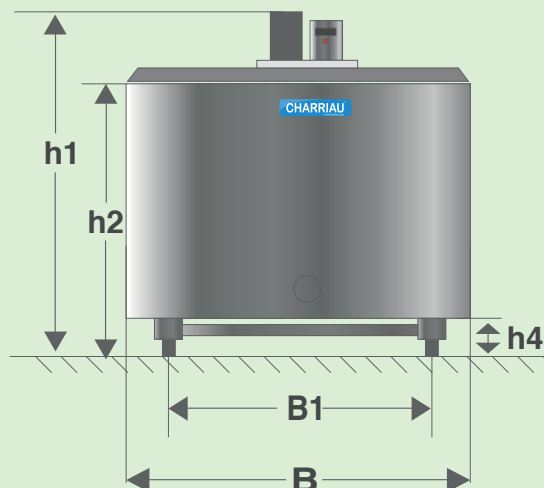

DIMENSIONS

Modèle Model	A	A1	A2	B	B1	H	h1	h2	h3	h4
IC1000	2350	1320	450	1495	910	1975	1250	1010	840	192
IC1250	2320	1320	450	1495	940	2090	1495	1150	840	192
IC1500	2320	1560	590	1495	1140	2250	1645	1300	818	192
IC2000	2320	1490	680	1840	1130	2260	1510	1200	880	192
IC2500	2320	1490	680	1840	1130	2450	1700	1390	1070	192

DÉTAILS TECHNIQUES TECHNICAL DETAILS

Modèle Model	Capacité maxi Maximum capacity	Poids Weight	Groupe frigorifique Cooling unit	Voltage tension	Gaz frigo Gas	Capacité réfrigér. Cooling capacity	Puissance max Maximum power rate	Courant nominal Run current	Courant max Maximum current	Traite Milking
IC1000	1081	285	FH4540Z L'UH	220V-240V 50Hz, 1~	R449	7822W 3Hp	3978W	18,59A	28,75A	2
IC1000T	1081	285	MTZ36 Maneurop	380V-400V 50Hz, 3~	R449	7497W 3Hp	3567W	7,59A	10,75A	2
IC1250T	1285	300	MTZ40 Maneurop	380V-400V 50Hz, 3~	R449	8246W 3,3Hp	4024W	8,64A	11,75A	2
IC1500T	1519	320	MTZ50 Maneurop	380V-400V 50Hz, 3~	R449	10652W 4,2Hp	4349W	8,91A	13,54A	2
IC2000T	2029	450	ZB45 Copeland	380V-400V 50Hz, 3~	R449	13526W 6Hp	5210W	11,51A	15,14A	2



10, rue des Peupliers
44270 SAINT ETIENNE DE MER MORTE
Tel ; 02 40 31 18 72 Fax : 02 40 31 18 73
www.charriau.com - contact@charriau.com